

Paul Harden, NA5N • na5n@zianet.com

Part 1

The Handyman's Guide to – HOMEBREW CONSTRUCTION PRACTICES From Copper to Manhattan

What is the difference between a QRPer and a Homebrewer? Not much, from what I have seen over the years. Where you'll find a QRPer, you'll generally find someone who loves to build his own equipment.

When it comes to homebrewing, there are two QRPer's that have set the standard (in my opinion). First is Bill Jones KD7S. Bill's homebrew gear, mostly crafted from ABS plastic, sets the standard that rivals professional equipment. Second is Jim Kortge K8IQY and his now famous 2N2/40 built *Manhattan style*. While this method of construction has been around for years, and many will argue who actually "invented" it, there is no doubt that Jim's 2N2/40 elevated it to a whole new level. The craftsmanship of these two master builders sets the standard many homebrewer's now strive to achieve.

Due to the continuing interest in these "build it from scratch" construction techniques, George Heron and

Joe Everhart asked if I could prepare a basic guide for the **Homebrewer** based on some of the gear I have built or seen – which I am pleased to attempt. However, I make no pretenses that this is the complete guide to homebrewing. More precisely, it might be called "*Homebrewing Using Copper*" – and for good reason. Copper clad is readily available at hamfests and from many vendors (I get mine from Electronic Goldmine). Copper clad is very easy to work with, not only for the "circuit board," but for the construction of the enclosure and front and rear panels. It is also the main staple of "Manhattan Style" construction. And, best of all – it's fairly cheap!

I have used copper clad and Manhattan Style for many years myself, both for my QRP homebrewing, and prototyping circuits at work. Examples of both will be presented here.

1. Let's Get Started . . .

MANHATTAN STYLE . . . What is it?

Simply put, **Manhattan Style** of construction uses small pieces of copper clad (the "pads") glued to the main copper clad circuit board (the "substrate") that serve as component mounting platforms. The electronic components are then mounted and soldered onto these pads. The main "substrate" board serves as the ground plane. Not only is this technique an easy and neat way to build a circuit, it also produces a very quiet circuit due to the solid ground plane.

When Jim Kortge, K8IQY, submitted his 2N2/40 at the FDIM building contest, one of the judges, Chuck Adams, K7QO, commented how the construction technique, with the IC's and electrolytic capacitors in neat rows, looked like an aerial view of Manhattan. Thus, Chuck is credited with dubbing it *Manhattan style* – the term it is well known as today amongst QRPer's.

Making the "pads." There are numerous methods to make the pads. The most popular and easiest is using a **nibbling tool** to *nibble* out small pieces of copper clad from a larger piece, as shown in **Figure #1**. A nibbling tool costs \$20 or less and used for making square cut-outs in 1/8" (max.) aluminum, such as for mounting a meter. The tool easily nibbles through .031" or .062" copper clad. The chards from the nibbling tool forms the pads, about 1/16" x 3/16". (Known as "chads" in Florida!).

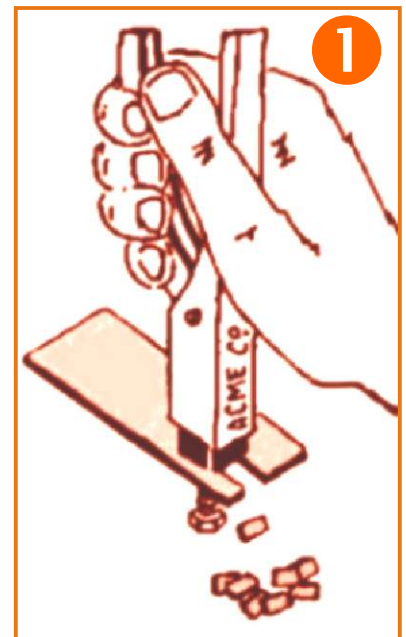

Using a nibbling tool

Others make round or circular pads with a **hand-punch** tool from Harbor Freight or other sources. Dies of various sizes can be purchased for the hand-punch tool, with 3/16" or 1/4" diameter being popular sizes. The tool punches-out holes in a piece of copper clad. The punched out material serves as the small, circular pads for Manhattan construction.

Still another method is to snap-off pads from a piece of **perforated copper clad board** as shown in **Figure #2**. The pads are twisted off with a pair of needle nose pliers or cut apart by a hefty pair of wire cutters. These pads are not as "pretty" as those made by a nibbling tool or circular hand punch, but work equally as well. The board can also be cut by following the perforated holes, using a coping or hack saw, to produce long strips, which can be cut-off at the desired length. One advantage of this technique is it allows you to make long strips that can serve as the +Vcc bus or making longer runs without having to connect two smaller pads with a jumper wire.

Pads can be made from .031" or .062" thick copper clad, single sided or double sided.

Once the pads are made, it's a matter of placing them on the main circuit board for mounting the components. Before gluing on the pads, it is best to plan ahead.

Laying out the circuit. It is recommended to lay-out your circuit on a piece of paper, arranging the components in a logical circuit manner, similar to laying out a printed circuit board with paper and pencil. This will ensure that all of the components will fit on the size of copper clad board you have selected as the circuit board or substrate. One can build Manhattan Style by "building as you go," but problems fitting components, working yourself into a corner, or ending up with long wire runs reaching front panel controls can occur. Planning ahead by laying out the circuit first is by far the best way to ensure the finished product is correct to the circuit, functional, and the final appearance is nice and neat.

Once this is done, transfer the layout to the copper clad board with a ruler and pencil as shown in **Figure #3**. This provides guidelines for gluing down the pads and keeping things straight, square and symmetrical.

Gluing down the pads. Once the circuit has been layed-out, it is time to mount the pads on the main substrate board with small drops of super glue, as shown in **Figure #4**. And, small drops is the secret! Learn to issue a very small drop, smaller than the size of the pad, to keep excess from being squeezed out over the board when you apply the pad. It takes a little practice, but you can learn to apply the right amount with little waste.

There are many opinions as to what type of super glue works the best. Some prefer one brand over another, some prefer the gels. I have tried them all and have found little difference between them other than personal preference. I build most of my Manhattan circuits with the cheapest glue I can find, which is usually Duro-Bond Super Glue, with two tubes per package costing \$1.79 or less at Wal-Mart or local hardware stores. The small "snout" on the tube is also relatively easy to keep clean and open.

The biggest problem I have found with different manufacturers or with the exotic applicators is keeping them clean. They work great – the first time.

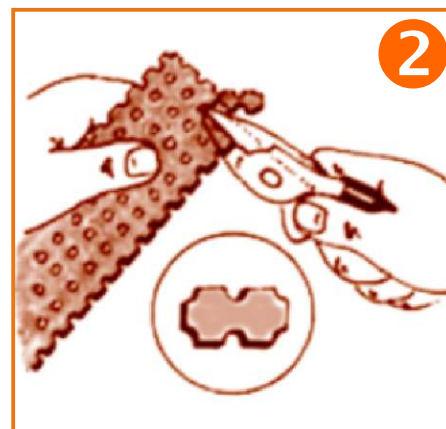

Using perforated copper clad circuit board for making the pads is another method, requiring no special tools.

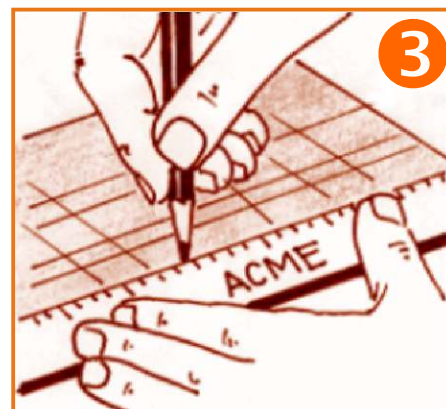

Draw footprints of each section and guidelines with pencil on the copper clad board. Planning ahead is important!



Pads are "mounted" to the main circuit board with glue – usually with super glue. The secret is learning to administer a small drop of glue. This comes with practice.

But, when you come back to work on the project the following night, that fancy \$5 tube has super-glued itself shut. You either can't get the protective cap off, or the tube has turned into a solid brick. Time for a new tube. A couple of cheap tubes of super glue goes a long ways when this happens.

To avoid these problems, I usually do two things when I'm done for the day:

- 1) Remove the applicator tip and run a resistor lead down the spout to open up the channel from excess glue. The excess may run or drip out the end. This will ensure the applicator tip is "open" when you place the tip back onto the tube. Without doing this, the super glue left in the tip can turn solid and hard, preventing it from being used again.
- 2) Clean the applicator tip and protective cap with a Q-tip or paper towel soaked in alcohol or acetone. Clean off all access glue, particularly on the threads for the protective cap. Then, clean dry with a piece of paper towel. If the paper doesn't stick – it's clean! This will ensure you'll get the protective cap off the next time you use the tube of glue.

These two simple cleaning steps can keep a tube of super glue useful for a long time. If not, that's why the cheap tubes of super glue should be used.

Positioning the "pads." The pad is placed on the drop of super glue and positioned into exact placement with an Exacto knife or other sharp object, as shown in **Figure #5 and #6**. For the first few seconds, the super glue will be slippery, allowing the pad to be easily positioned. Once in the desired position, push down on the pad against the main board to squish against the glue. It will be solidly glued into place in a few seconds.

The method I often use is to place the pad into position with a pair of sharp, needle nosed tweezers. Once in position, I push down on the pad with a small screw driver or the wooden shaft of a Q-tip. However, the tweezer method does not work well when using the punched-out circular pads.

After several seconds, the pad should be firmly attached to the substrate board. Some of the circuits I have built years ago using this method have the pads still firmly affixed to the board.

To remove a pad that got positioned in the wrong place, simply "twist it off" the board with a pair of needle-nosed pliers, as shown in **Figure #7**. Any pad that becomes dislodged from the board can be simply re-glued into place with a new drop of glue and holding in place for a few seconds.

Cleaning up. Once the excess glue had dried, it can be scraped off the board with a hobby knife or a small flat blade screw driver. It's up to the builder how picky one wishes to be with this. At a minimum, the board and pads should be cleaned with a hobby brush or toothbrush moistened with alcohol or acetate to remove oils, fingerprints and debris. This will make for easier soldering and a nicer appearance.

Acetone dissolves dried super glue better than alcohol. It is easily obtainable as fingernail polish remover in many stores. However, most fingernail polish remover sold today is "acetone free." Ensure you get a bottle that contains real acetone. I get a bottle of acetone based fingernail polish remover from Wal-Mart that works quite well. It costs 88 cents for a pint bottle and usually lasts for several projects.

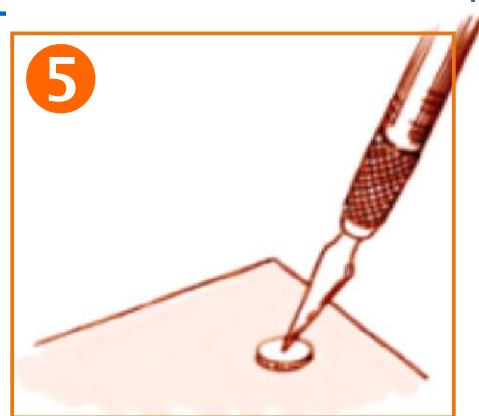

Place the pads onto the drop of glue and position with an Exacto knife, other sharp object or tweezers..

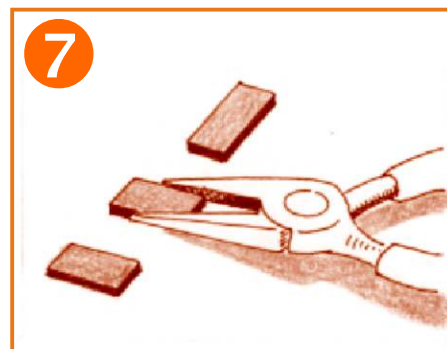

Remove a pad by a twist with a pair of needle-nosed pliers.



Clean board and pads with a brush and alcohol or acetone.

Melt solder! Once the pads are in place and cleaned, there is nothing left to do except mount the components onto the pads and solder in place according to the layout drawing. Of course, ground connections are soldered directly to the main substrate board, being the circuit ground plane, as shown in **Figure #9**.

I use a small hobby brush with hair or fiber bristles (not steel) for cleaning the pads. I use the same brush moistened with alcohol or acetone for cleaning the pads after soldering. This removes excess flux and debris, leaving a nice, shiny soldered pad.

Tools. In addition to the obvious — a soldering iron, wire cutters and the small pliers already discussed, several other small tools come in handy:

Tweezers are handy for positioning the pads when gluing to the board, in addition to holding small parts while soldering – particular surface mount components. (*Surface mount techniques will be presented in Part 2*).

Hemostats are another useful small tool for holding resistors or capacitors while soldering. They are locking, making it easy to hold the component with one hand while soldering with the other. Just ensure you don't over-squeeze the component to cause damage. Hemostats often allow a component to be held with a better grip than with tweezers.

Small screwdriver, flat-blade or phillips, is useful for holding down pads while the glue dries, pushing down ill-bent or stubborn component leads while soldering – even a lead bender to ensure smooth bends on component leads and internal wiring.

Q-tips are handy for cleaning or scrubbing around the pads after soldering, where a hobby brush may not often reach. Lightly moistened with alcohol or acetone, they are also useful for cleaning the components. When cut in two, the wooden shafts are also handy for holding down pads during gluing, or components while soldering.

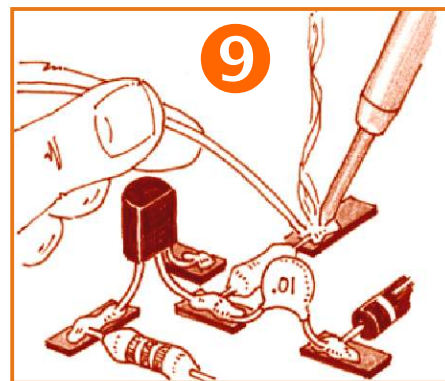

The glued pads become the mounting platforms for the components, soldered in place.



Some of the small tools useful when building Manhattan style.

2. Some Practical Examples

THE ROCKMITE QRP TRANSCEIVER

Like hundreds of others QRPers, I built a **Rockmite** about two years ago when the kit was first introduced. The Rockmite QRP transceiver is a kit from Small Wonders Lab, furnished with a printed circuit board. I decided to highly modify mine, building it in a custom enclosure with a set of homebrew built-in paddles, something I always wanted to do. Additionally, it served as a test platform for a 5W Class-E PA circuit. The entire rig, including the paddles, was built of copper clad, except for the top cover, made from a scrap piece of perforated aluminum and painted black.



Fig. 11

The front panel, shown in **Figure 11**, was made from a piece of copper clad. Holes were drilled and the “square holes” for the power switch and paddles were filed to shape with a small jewelers file. After drilling, the copper clad was brushed with emory paper to rough up the copper a bit before applying a light coat of gray primer paint. The second coat, applied the following evening (this is a big hint for painting enclosures!) was a coat of light avocado green. The following evening, when fully dry, the light blue trim and boxes for the transmitter drive and receiver RF gain controls were painted by hand using a small brush. The legends were applied using rub-off

letters and sealed with a light coat of Krylon Protective Spray – available at many office supply or art stores. Clear enamel can also be used, but always test first on a scrap piece of material to ensure it doesn't "melt" the rub-off letters.

The front and rear panels were soldered to a copper clad "center" shelf, mounted about half the height of the two panels. This shelf serves to mount the Rockmite PCB and the paddles on the top (see **Figure 12**), and the transmitter components on the bottom.

The paddles are made entirely of pieces of copper clad, including the paddle pieces, as shown in the photograph of the top view. A 4-40 bolt and nut, with a spring from a BIC pen, formed the tension on the two paddles, while two other 4-40 machine screws serve as the dit and dah contactor and sets the spacing. It's not exactly a work of art, but they worked well, enough to have around 50 QSOs with this rig.

The transmitter was built Manhattan style, with the pads glued directly to the bottom of the copper clad shelf. The IRF510 was mounted to an island cut-out of the copper clad by a Dremel tool. Since the IRF510 tab is the drain, this isolated the +12v on the drain tab from ground. Most of the interconnecting wiring was performed by using flat ribbon cable as shown in **Figures 13 and 14**.

The intent of this particular custom-made Rockmite kit is to show the flexibility of copper clad. It was easy to form the copper pieces into the desired front and rear panels, the center shelf, and even the paddle pieces. Granted, it took a little cutting and filing to form some of the pieces, but far easier than forming the same pieces from aluminum or metal stock. Plus, it can all be easily soldered together.

By applying a light primer coat before the final color of spray paint, copper clad makes an attractive and durable front panel as well.

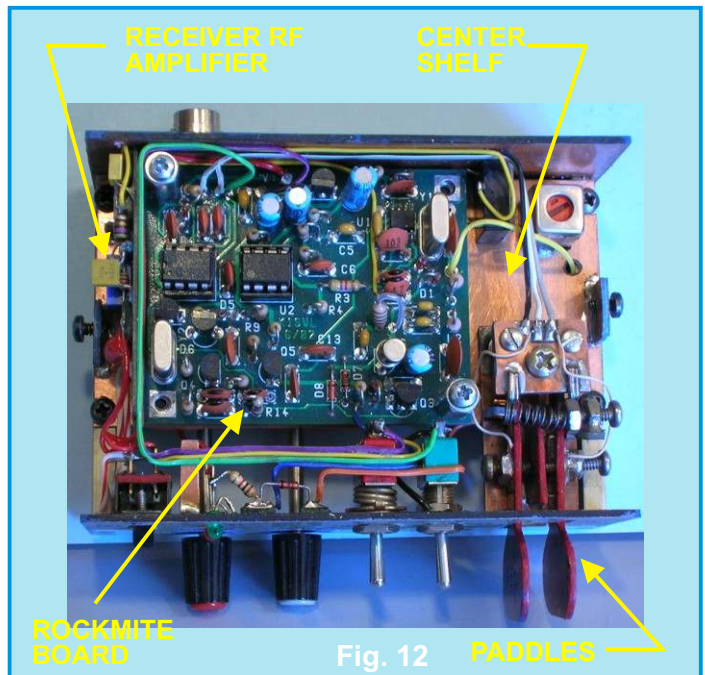

Fig. 12 PADDLES

Top view of the Rockmite. The Rockmite PCB and the homebrew paddles are mounted on the top portion of the center shelf.

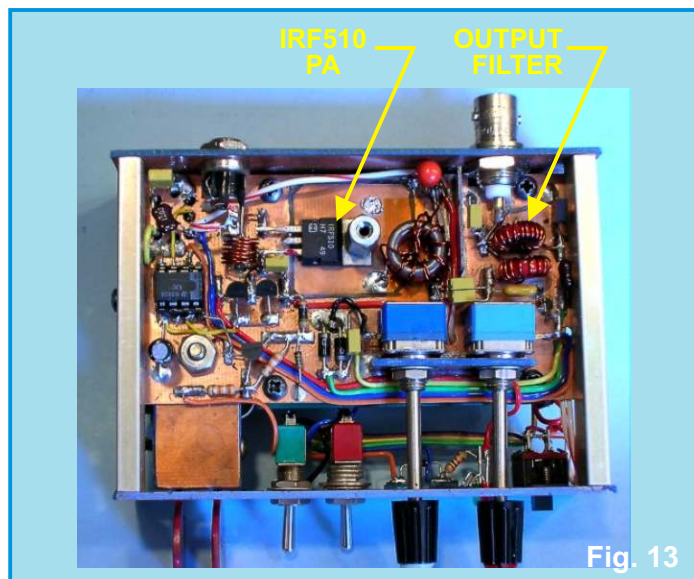

Fig. 13

Bottom view of the Rockmite, showing the homebrew transmitter section built Manhattan style.

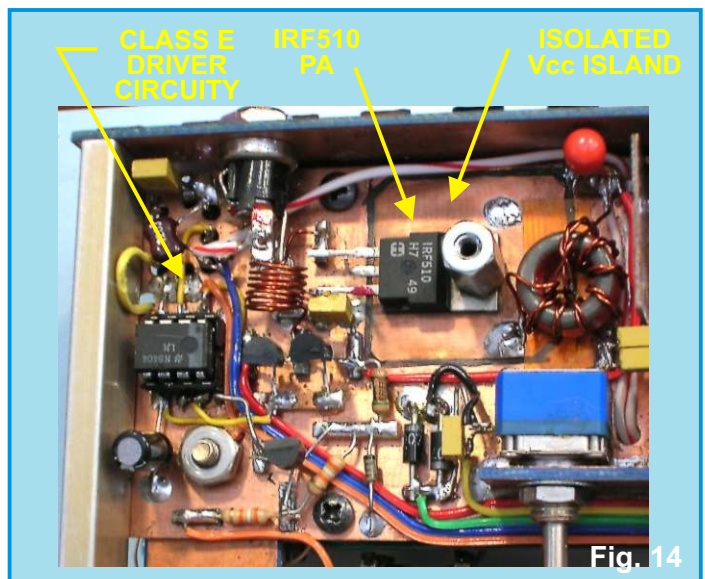

Fig. 14

A closer view of the transmitter section, showing the Manhattan style of construction.

MANHATTAN STYLE HOME BREW TRANSCEIVER

I have built several QRP transceivers on different bands Manhattan style, mostly my own designs. In fact, that is one of the advantages I have found with Manhattan is how adaptable it is for a test platform. Changing components of different values to set proper biasing or gain is relatively easy, as is making circuit changes. Of course, too many circuit changes can get ugly as you try to fit things in you didn't originally plan on. But, it usually works fine. In the circuit shown here, I converted the RF amplifier from fixed gain to an AGC driven stage, moving around a few components from that originally planned.

The schematic (**Fig. 15**) is the "front end" portion of a 40M receiver I built, where T1 and T2 are Mouser 421F124 IF cans. Q1 is a common base amplifier with the bias via R2 from the AGC line. C1 and C2 are the tuning capacitors to resonate T1 and T2 at the desired frequency (T1, T2 are 4.5uH nom. with no internal tuning capacitor). T1 is made resonant at the RF frequency and T2 at the IF frequency. Built Manhattan style, this RF amplifier and mixer scheme was fairly sensitive with a good noise figure.

The **Figure 16** photograph shows the "front end" portion of the receiver, based on the above schematic. With a little layout on paper first, the RF amplifier, receive mixer and 1st IF amplifier fits in an area about 1 x 2.5 inches. Interestingly, I also built a surface mount version of this same receiver, using the same IF transformers, and it took only about 1/4" less space! I used SOT-23 SMC 2N3904 transistors, which are about the same width as the TO-39 plastic versions. As a result, little space savings was noted – at least using this layout configuration.

The IF transformers are mounted on the main board in standard Manhattan style. See **Figure 17**. The only caution is to ensure the IF "can" is soldered to the main board with either the mounting tabs (if they reach) or with a piece of solid bus wire or a scrap resistor lead folded in two. Solder on two adjacent sides of the IF can for a firm mechanical connection.

Likewise, ground the desired pads(s) by soldering a wire or resistor lead to the main board for grounding. All transformer pins should go to a Manhattan pad to keep the IF transformer "level." Soldering the wire to ground the pad(s) to the main board also helps with the mechanical mounting without depending solely on the super glue. Otherwise, with a "stiff" IF can, you can twist the pads off the board while adjusting the center slug if not soldered directly to the board.

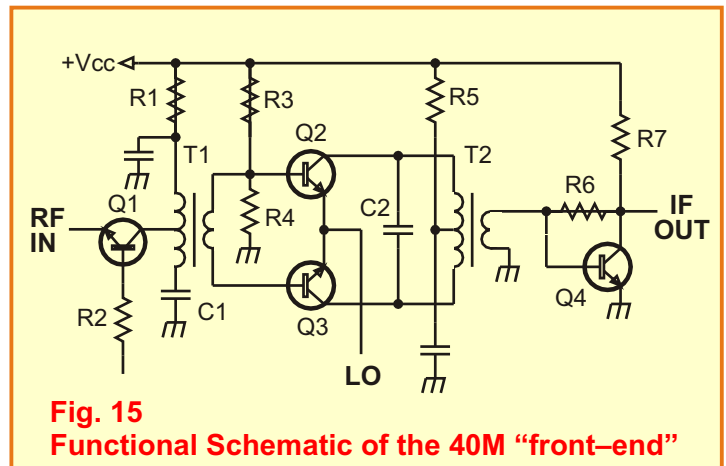

Fig. 15
Functional Schematic of the 40M "front-end"

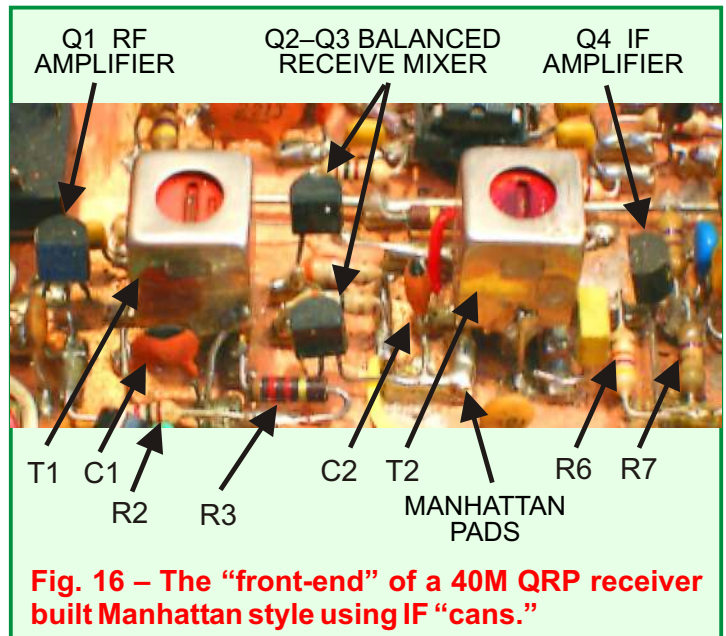
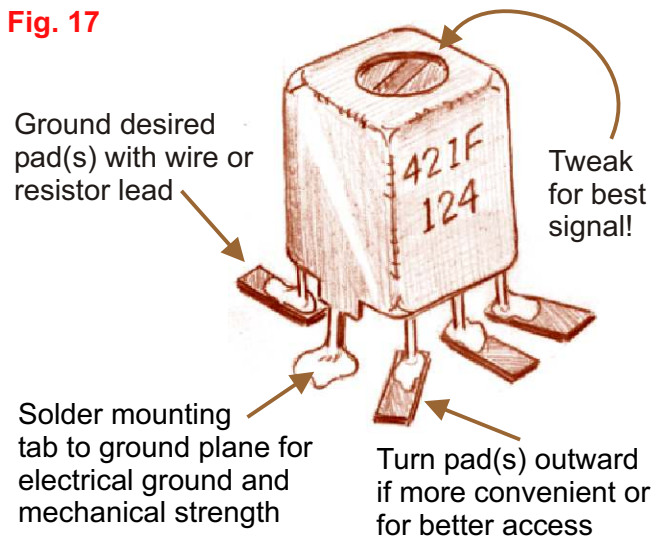

Fig. 16 – The "front-end" of a 40M QRP receiver built Manhattan style using IF "cans."

Fig. 17



Mounting IF Transformers Manhattan style

Following the 1st IF amplifier is the crystal ladder filter, as shown in **Figure 18**. Four of the crystals are for the IF filter, the one on the far left is actually the crystal for the transmit oscillator. The transistor in the upper left of the photograph is Q4, the 1st IF amplifier in **Figure 16** on the previous page. The wire soldered along the tops of the crystals serve two purposes: 1) to ground the cans to the main board, and 2) provide mechanical rigidity. Without this ground wire, I find myself constantly bending over the crystals while I'm building and poking around in the circuit.

Figure 19 shows in a bit closer detail how the crystals and shunt capacitors are mounted to the Manhattan pads.

In mounting the crystals on standard Manhattan pads, the crystal leads need to be bent to fit. This is a case where cutting small strips of copper clad to length makes for a neater and more accessible assembly.

Figure 20 shows the LM386 audio output amplifier I.C.. This is such a simple, yet effective audio amplifier, it has become the benchmark amplifier in most QRP rigs.

I mount ICs either on individual Manhattan pads, or build a single pad as shown in the photo of **Figure 20**. This pad is made from a single piece of copper clad, cut into the pads as shown by sawing away the copper between the pins with a hack saw, coping saw, or a Dremel tool with a cutting disk. Then, obviously, another cut down the length of the IC to separate pins 1–4 from 5–8. Either method takes about the same amount of time, though the single Manhattan IC pad does look nicer, in my opinion.

If you make a rig out of copper clad, including the front and rear panels, don't forget the copper on these surfaces can be used as well. **Figure 21** shows one rig I built with the PA output filter mounted on the inside of the rear panel, next to the Antenna BNC connector. In this particular case, I etched away the unwanted copper with a Dremel tool, though Manhattan pads could just as easily be used. To the left of the filter (not shown) is the TO-220 PA transistor – also mounted on the inside rear panel. This allows the rear panel to serve as a large heat sink.

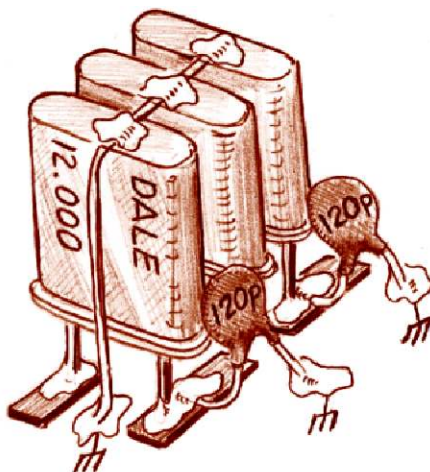
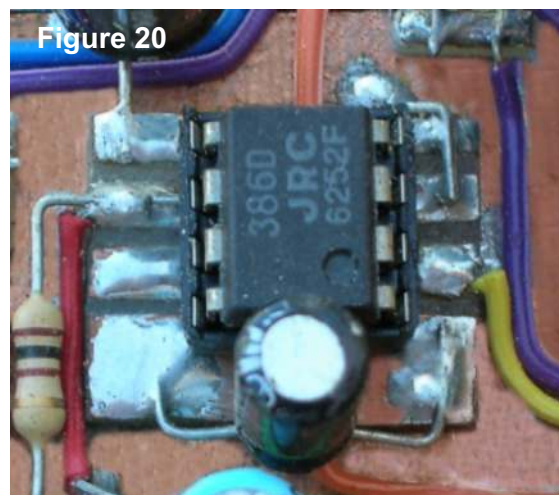

Figure 19



The IF Crystal Filter



The LM386 Audio Output Amplifier IC



The PA Output Filter mounted on the inside of the rear panel saves space

A MANHATTAN BUILDING JIG

One of the difficulties I've experienced building small circuits is the copper clad board, weighing only a couple of ounces, moves all over the workbench surface as you work on it.

Shown in the photograph is a Manhattan Building Jig (MBJ) I built for holding down a circuit board while it is being built and tested. In this case, I used a piece of aluminum and milled out several slots. In these slots ride the screw heads for the threaded standoffs. On the top of the standoffs, the washers and nuts secure the circuit board. Once attached, the screws on the bottom of the plate are tightened to hold everything rigidly in place. This allows different sizes of circuit boards to be mounted onto the jig. I have found this simple jig to really ease construction and testing. Particularly testing. Once you get a couple of cables and wires connected to the board, the weight of the cables alone will pull the board right off the bench! A jig with a little weight and larger footprint will keep this from happening.

On the far right hand side of the jig, under the circuit board and hardly noticeable, is the TO-220 voltage regulator used for the circuit. This places the voltage regulator close to the circuit and the base acts as a heat sink.

Of course, a jig of this nature could be built out of plywood or even a piece of 2x4. In this case, the board is held down to the jig with wood screws or other fastening scheme.

MANHATTAN – VHF STYLE

One of the “modules” I am responsible for at the VLA observatory is called the “4/P Converter.” This converts our low-band receivers, being 74, 196 and 308–348 MHz, to an IF of about 1.1–1.4 GHz (L-band), then upconverted again to our 8–12 GHz X-band IF. In order to checkout this upconverter, I would need 4 signal generators, one for the three receivers and one for the 1024 MHz LO. I'd get killed by my co-workers for sucking up 4 of the lab signal generators everytime I needed to work on this converter! And, I've got 28 more of them to build over the next 3 years. So, I designed and built a test set that simulates the three receivers and the 1024 MHz LO. Additionally, it contains a sweep generator for “sweeping” the bandpass shape of the RF and IF filters on a spectrum analyzer.



Fig. 23 – A Manhattan-built Test Set used to simulate three VHF receivers and contains a 1024 MHz Local Oscillator

This was a fun “ham radio” project at work. It was built largely from copper clad and Manhattan style. Most of the parts were ordered from Mouser, All Electronics, Electronics Goldmine and MiniCircuits. The overall “4/P Band Test Set” is shown in **Figure 23**. The copper clad circuit assemblies are mounted vertically with the push-button switches and potentiometer controls protruding through the front panel. Details of two of these assemblies, the 74MHz oscillator and the 200-400MHz sweep oscillator, are shown on the next page. The meters indicate the output power level, normally set to –35dBm to simulate the receivers. While this is not a ham radio QRP project, it does contain many construction techniques that can be applied to any HF or VHF project. (Although, it was

built by a QRPer!). When I built this, I was a bit concerned at how the copper clad and Manhattan pads would behave at the VHF frequencies..It turns out, it works quite well. Wideband sweeps reveal only minor gain “suck-outs” between 600-1500 MHz. Rumors that Manhattan style should not be used above about 20MHz are thus unfounded, as proven with this project.

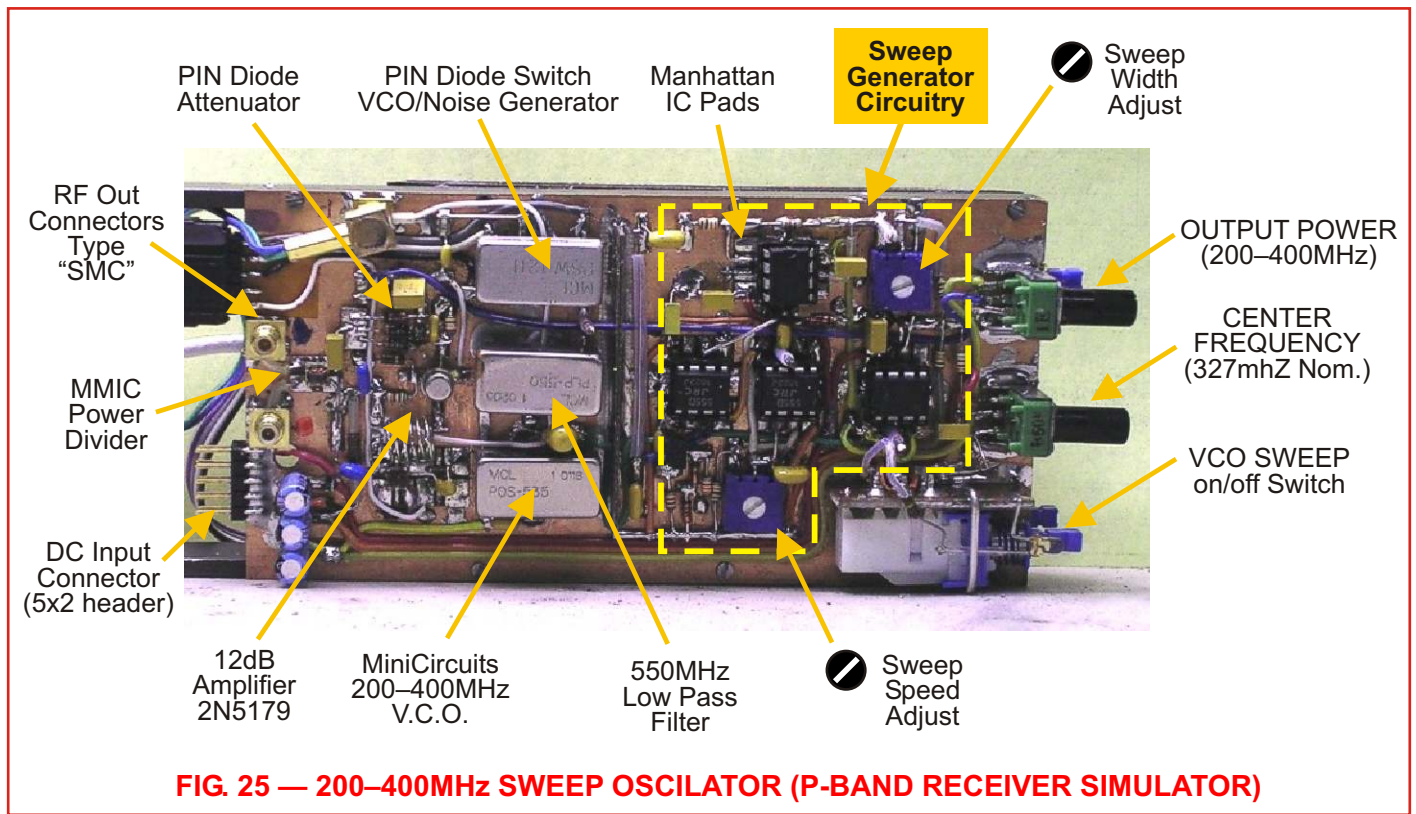
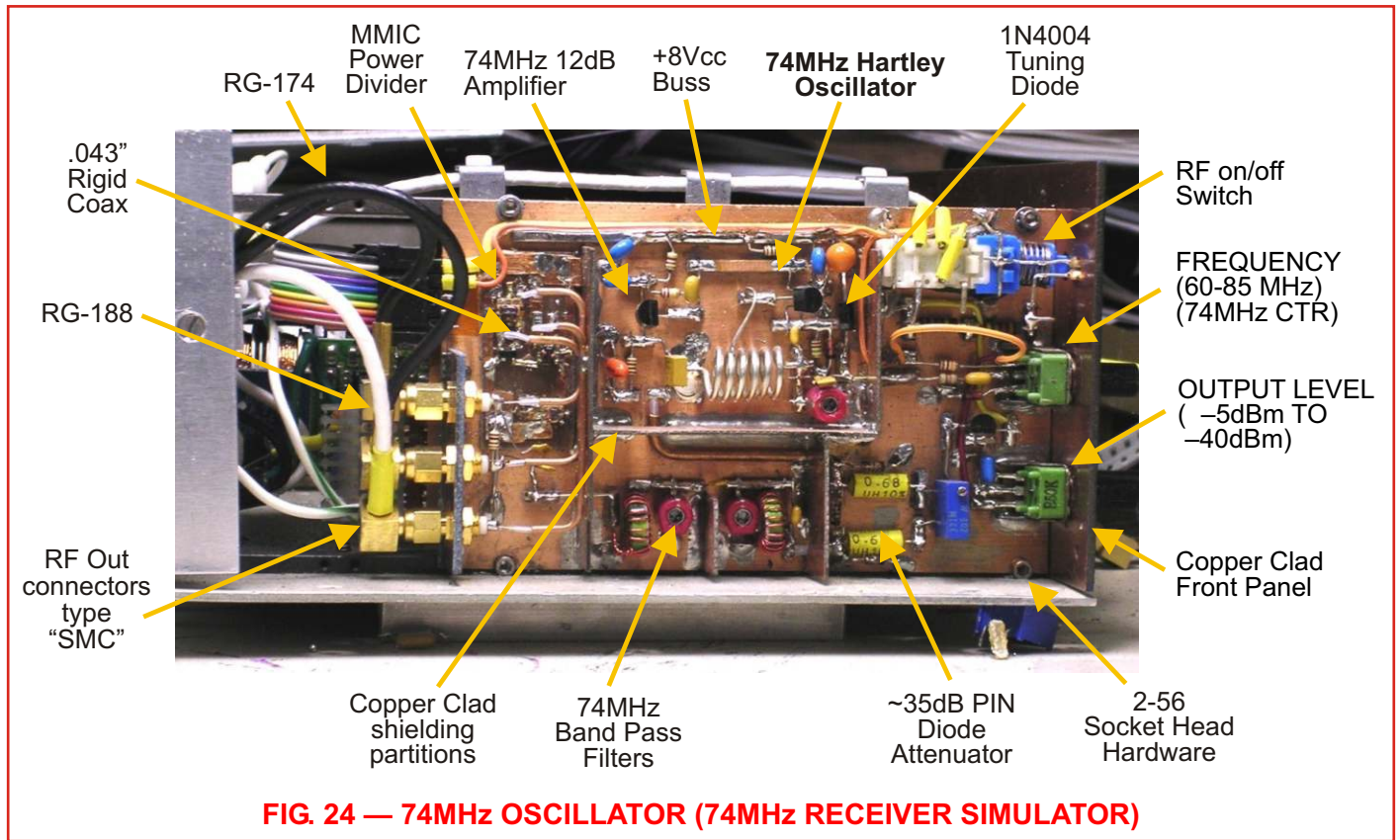

3. “Ugly” or Manhattan?

While the majority of this article focuses on Manhattan style of construction, it is not the only means to build a circuit. Since the dawn of radio, hams have built equipment “ugly style.” Ugly has a charm of its own.

Ugly began in the earliest days of vacuum tubes, where a circuit was built on a piece of smooth wood, mounting components between nails or screws – often just twisting the wires together, not soldered. Since a cheap piece of attractive wood in the early 1900s was a breadboard used by bakers, the term for this style of construction was called “breadboarding” – the genesis of the term still used today for building a one-of-a-kind circuit. Building on a breadboard could be anything from beautiful (**Fig. 26**) – to outright ugly.

Basically, building something ugly means “just throw it together” with little regard to appearance. Ugly also tends to imply building it cheaply as well, a common attribute of most hams – yesterday as well as today.

Today’s breadboard tends to be a piece of copper clad. Component leads that are grounded are soldered to the copper clad surface as in Manhattan style. Everything else just gets soldered together, often with the components hanging in mid-air. The only concern is to make sure the component leads do not touch ground or other things they shouldn’t – often by bending or routing leads and wiring in a precarious manner. An example of this is the 7 MHz VFO built “ugly” as shown in the photograph of **Figure 27**.

A variation of the ugly circuit is called “dead bug.” This technique is where the integrated circuits (the “bugs”) are glued (or not) to a surface, face down, with the IC pins sticking up in the air for easy access. Wiring and components are soldered directly to these pins.

Regardless of the ugly method used, the circuits usually perform quite well. The biggest problem is stray capacitance from the often long component leads and wiring hanging in mid-air and in close proximity to each other. However, once the circuit is “tuned” to account for the stray capacitance, the circuit will work reliably – as long as you don’t move or rearrange anything!

This becomes one of the biggest problem in ugly construction – duplicating the circuit. It often works fine for the first person building it, but when the circuit is built by someone else, results may vary. This is why early QRP publications seldom detailed how the circuit was built, as it was difficult to document to show exactly how the circuit was built.

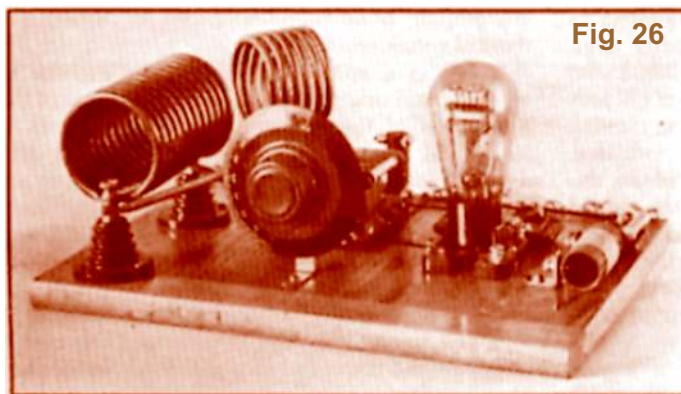

Fig. 26

From 1933 ARRL Radio Amateur's Handbook
Early ham equipment was often built on a standard 10 x 12.5 inch bread board, such as this 1930s “7000 kc low-power transmitter.”

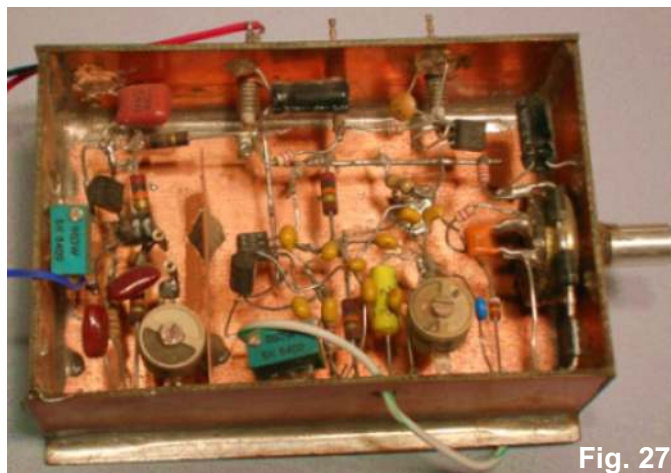

Fig. 27

The modern “breadboard” is often a piece of copper clad. This 7.0 MHz VFO was built “ugly style” in a copper clad “box.”



Fig. 28

A regenerative receiver built ugly style on a piece of copper clad. The coil is wound on an IC shipping tube.

In my opinion, this is the strongest advantage of Manhattan style for QRPers ... it is easy to document. Photographs or drawings illustrate exactly where each component goes and how it is built, ensuring consistency in construction amongst the various builders. This consistency also ensures the performance of the circuit will be about the same from unit-to-unit. This is why those people building Jim Kortge K8IQY's 2N2/40 were so satisfied with the results. Those who built it from the detailed drawings in the original QRP article, the book, or on Jim's website, all ended up with a hot 40M transceiver with very similar performance to Jim's original. Had the 2N2/40s been built "ugly," this consistency in performance could not have been guaranteed. How would you document with any degree of accuracy the "ugly" circuit shown in **Figure 29**?

This is why Manhattan style has become so popular with QRP homebrewers. The designer can *clearly* illustrate *exactly* how to build the circuit to guarantee the expected results. The builder has *precise instructions* to follow and can build the circuit with the confidence it will work. This is true with the seasoned builder as well as the beginner. This is why Manhattan style has become the biggest boost to building a circuit "from scratch" by QRPers. Circuits designed and built Manhattan become excellent construction articles, since the step-by-step instructions lie mostly in the illustrations or photographs.

This is not to say building a circuit "ugly" style is inferior. As already mentioned, problems can occur in attempting to duplicate the circuit. However, for

4. Conclusion

As most homebrewer's will tell you, there is nothing like the feeling of building a QRP rig and the thrill of having that first QSO with it. Whether you build ugly, a kit, or Manhattan style, QRPers will always be building their own equipment. This is why some of the QRP clubs and various vendors provide kits for building your own QRP transceiver. And, for those wishing to build a rig from scratch, this is why the QRP journals like the **Homebrewer** present as many construction articles as they can on the subject of homebrewing.

This article is intended for both the experienced builder and the new comer. If you've never built anything from scratch before, build a simple circuit using these techniques to "get your feet wet." AmQRP is committed to homebrewing. There will continue to be construction projects of different skill levels in future issues of the **Homebrewer**.

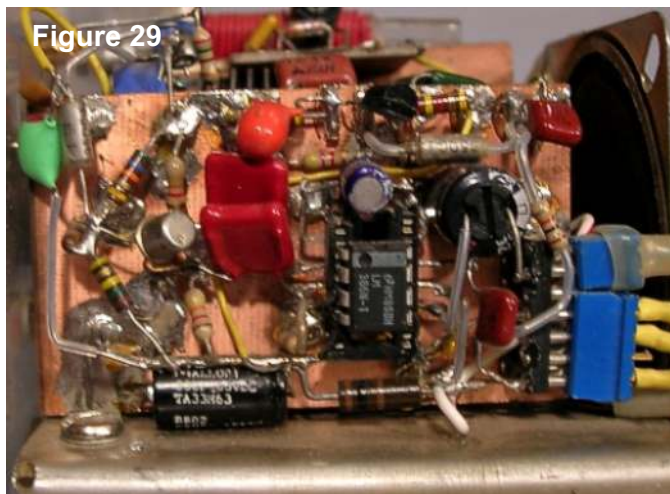

Figure 29
The AM detector and audio amplifier portion of a shortwave receiver built "ugly" style. The unused end pins of the IC socket are soldered to the copper clad. The remaining socket pins are bent outward to make the connections.

building a one-of-a-kind circuit, ugly can be a quick, cheap, dirty way to get it built and get it on the air. Over the years, I have had many QSOs with homebrew rigs built ugly. A couple were really ugly! The classic "Ugly Weekender" 40M receiver by Wes Hayward W7ZOI and Roger Hayward KA7EXM is a good example of a very nice performing rig built ugly style. It was featured in the 1992 Radio Amateur's Handbook and in the ARRL's book "QRP Power."

There are few rules in building ugly. You simply "do your own thing" and get it working.

In Part 2 – we'll continue with some of the construction practices employed in building circuits from scratch, including an emphasis on building with surface mount components, some various "hints and kinks," and a photo gallery of what others have built.

I am not a master builder of Manhattan. I never dreamed some of the stuff I've built would be featured in an article – or else I would have built them a little nicer! If you've built something from scratch, ugly or Manhattan, feel free to send me a photo or two to include in Part 2 to show what others have built, and how they built them. Likewise, if you have a construction hint or kink, send it to me and I'll gladly illustrate it for the next issue.

72, Paul Harden, NA5N
na5n@zianet.com